

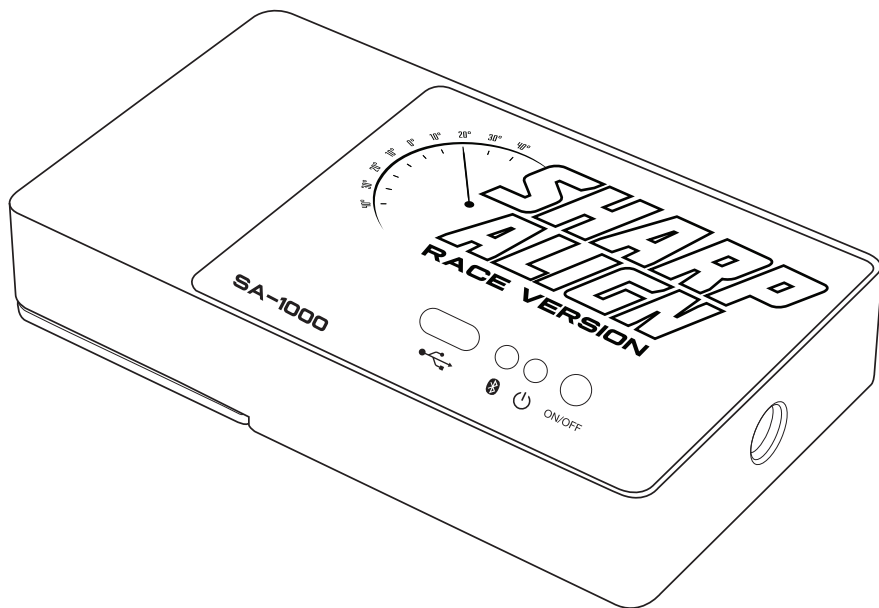

SHARP ALIGN

RACE VERSION



SA-1000

USER'S MANUAL

Overview:

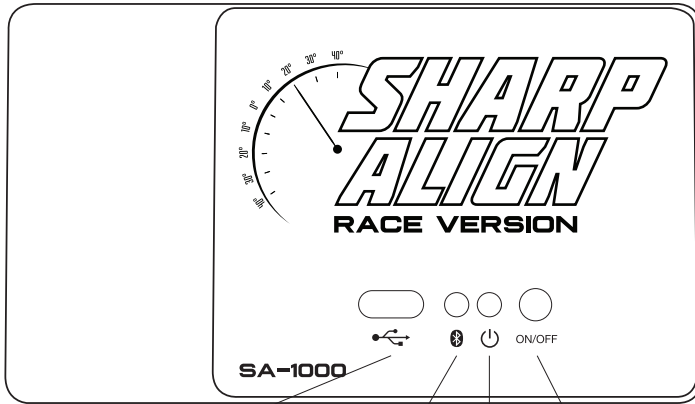

**Micro USB
Charging Port**

**LED Power
Indicator**

**LED Bluetooth
Indicator**

On/Off Switch

LED		
RED (charge LED)	On	Charging in progress and device can not power on with microUSB connected.
	Off	Charge complete with microUSB connected.
GREEN (Power LED)	On	Device power on normally.
	Off	Device power off.
	Flashing Slowing	Power LED on/off toggle every 1 second. This indicates low battery occurred. User must change batteries if using non-rechargeable batteries or charge batteries if using rechargeable batteries.
	Blink Quickly	Power LED blink for 2 seconds and LED off for 2 seconds repeatedly indicate device power on fail. User must power off device and power on again.
Yellow (RF LED)	On	Bluetooth connected.
	Off	Device power off.
	Flashing	Flashing slowly indicate Bluetooth broadcast.
	Blink Quickly	Blink quickly indicate RF power on fail. User must power off device and power on again.

Features

- Displays steering angle in real time
- Interactive on-screen instructions guide you through the process
- Get measurements in minutes
- Bluetooth automatically connects when Sharp Align app is open
- Detailed reports saved
- Easy to compare data in list view
- Add photos and notes to each report
- Live camber reading screen

Technical Specification:

Steering Angle (S.A.)	
Minimum Steering	$\pm 18^\circ$
Accuracy	$\pm 1.5^\circ$, S.A. $< 45^\circ$

Camber	
Range	$\pm 25^\circ$
Resolution	0.1°
Accuracy	$\pm 0.2^\circ$, S.A. $< 15^\circ$ $\pm 0.3^\circ$, S.A. $< 25^\circ$

Caster	
Range	$\pm 25^\circ$
Resolution	0.1°
Accuracy	$\pm 1.5^\circ$

Temperature	
Operation	$0^\circ\text{C} \sim 50^\circ\text{C}$
Storage	$-10^\circ\text{C} \sim 60^\circ\text{C}$

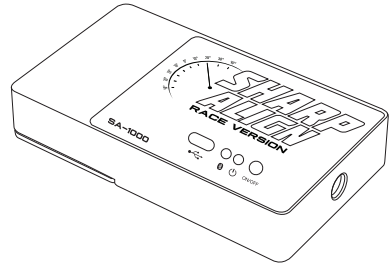

Battery	
Battery Type	AAA x2 Chargeable or Primary
Consumption	123mW, (operation)

Communication	
Bluetooth LE	V4.0
Range	10M / 30ft.

Dimensions	
Sensor Dimensions	4.33" x 2.48" x .78"

Operation

1. Download App

Look for and download the Sharp Align Angle Sensor App on your smart device



2.1 Connecting the sensor to your smart device



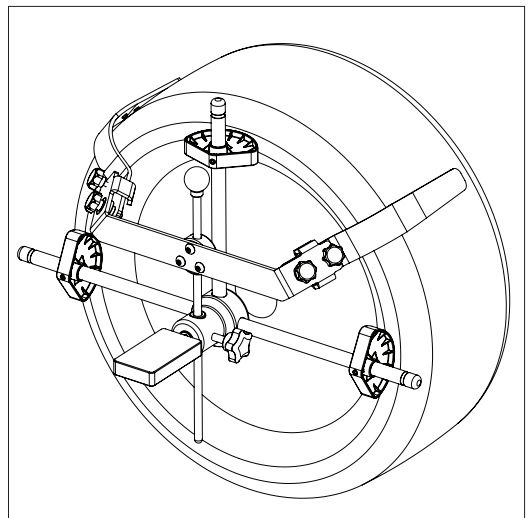
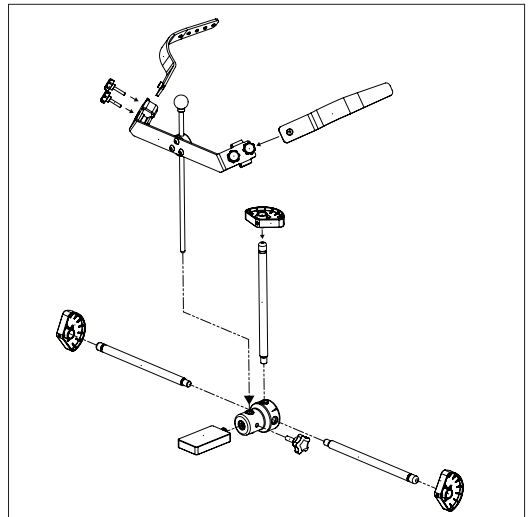

If your Bluetooth is turned on, search for the Sharp Align sensor and connect. When the yellow light on the sensor is steady on, your device has connected.

2.2 Fixture Assembly



Operation

3. Open Sharp Align App / Main Menu

- 3.1  **New Measurement:** Starts the measurement process to get a caster and camber on the left and right wheel.
- 3.2  **Live Camber Angle:** Reads a real-time camber angle for fast viewing.
- 3.3  **Report:** View a list of previously saved reports
- 3.4  **Settings:** Allows you to select a device and calibrate the sensor.



3.1 New Measurement

Follow the interactive on-screen instruction to obtain your camber caster reading.



- 3.1.2 Allow Sharp Align to calibrate. Once calibrated, a Camber reading will show.



Operation

3.1.3 Follow the on-screen instructions.
Turn wheel to the left (>18°) and HOLD

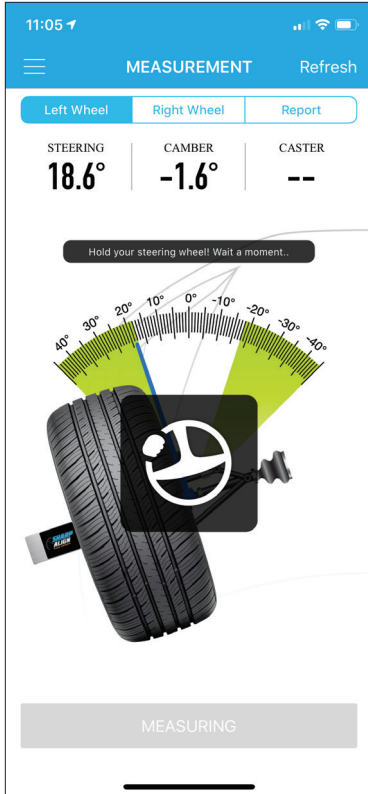

3.1.4 When instructed, turn the wheel to the right (>18°) and HOLD.

When measurement is complete, a Caster reading will show.

Repeat the process on the Right by selecting the “Right Wheel” tab at the top

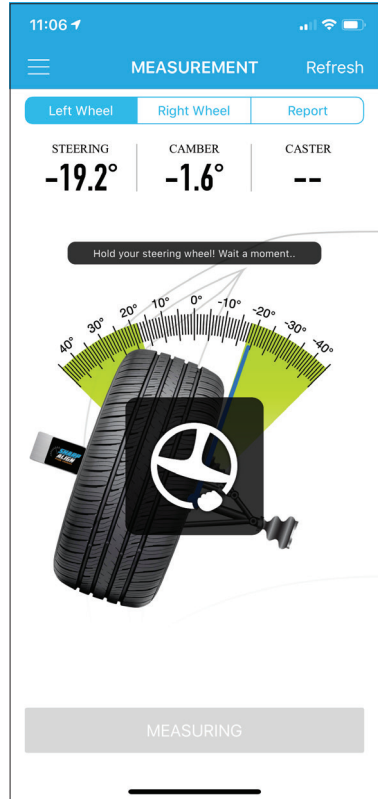

Operation

3.1.5 Measurement Complete. You can let your steering wheel go back to 0°.

- ▶ Select the “Report” tab to view the report
- ▶ Select the “Restart” button to restart the measurement



3.1.6 View Report

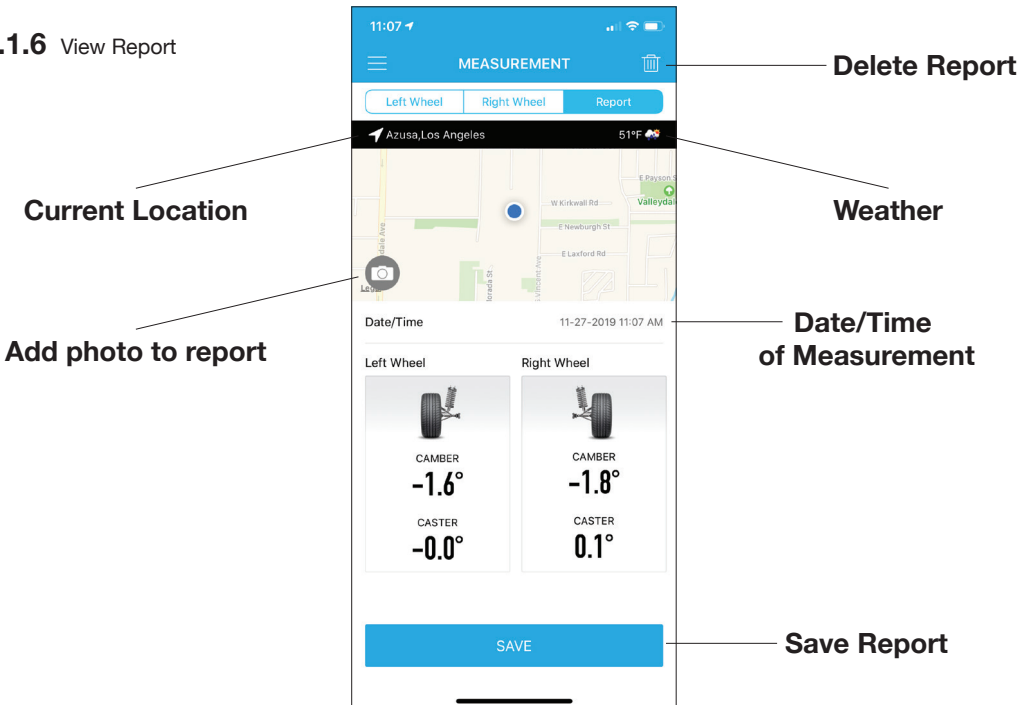

3.2 Live Camber Angle

- ▶ Reads a real-time camber angle for fast viewing.

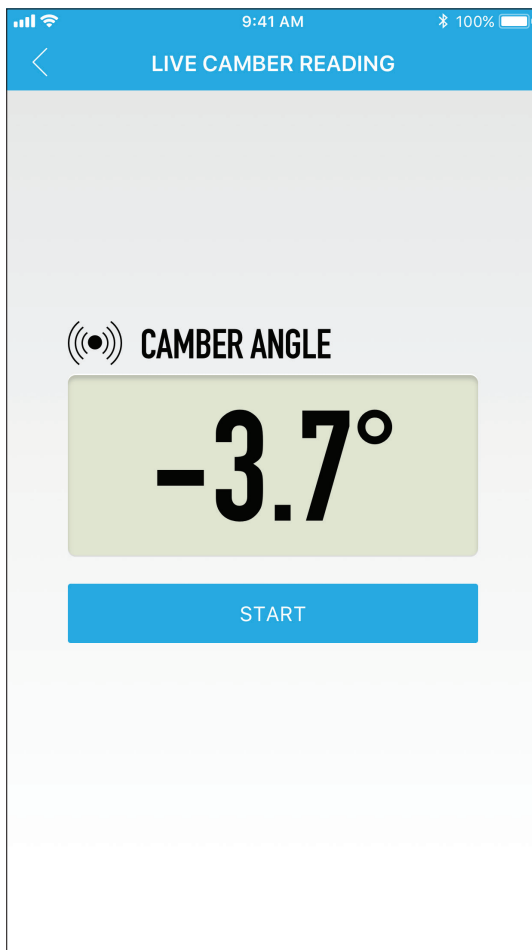

3.3 Reports

- ▶ View a list of previously saved reports.
- ▶ Select a report to see more details.

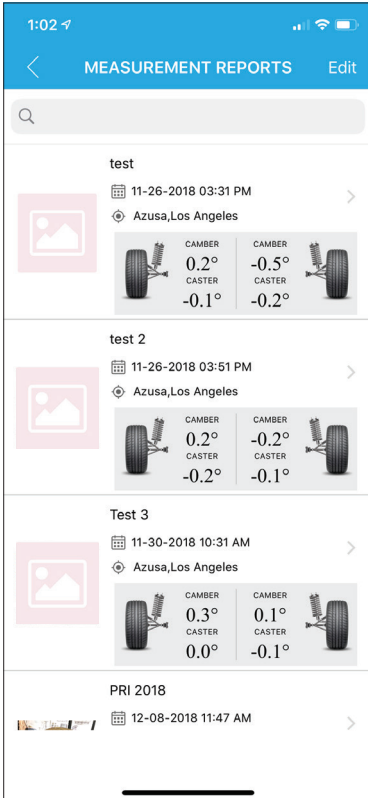

3.4 Settings

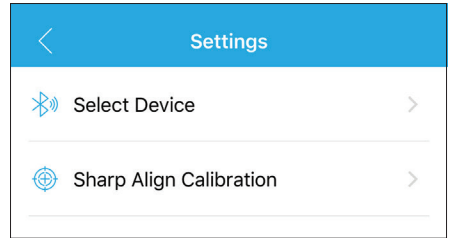

3.4.1 Select Device

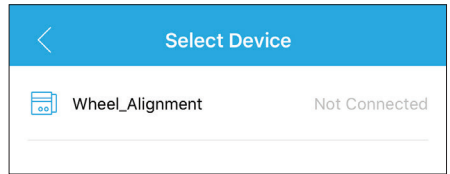

3.4.2 Calibration

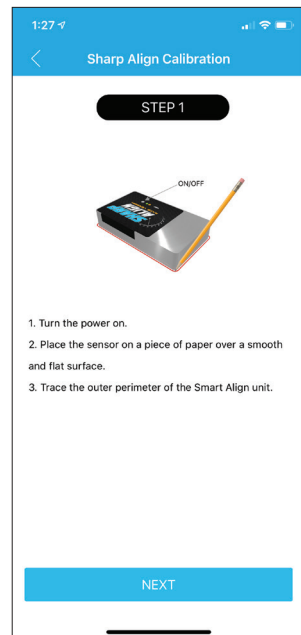

Sharp Align Universal Fixture Parts List

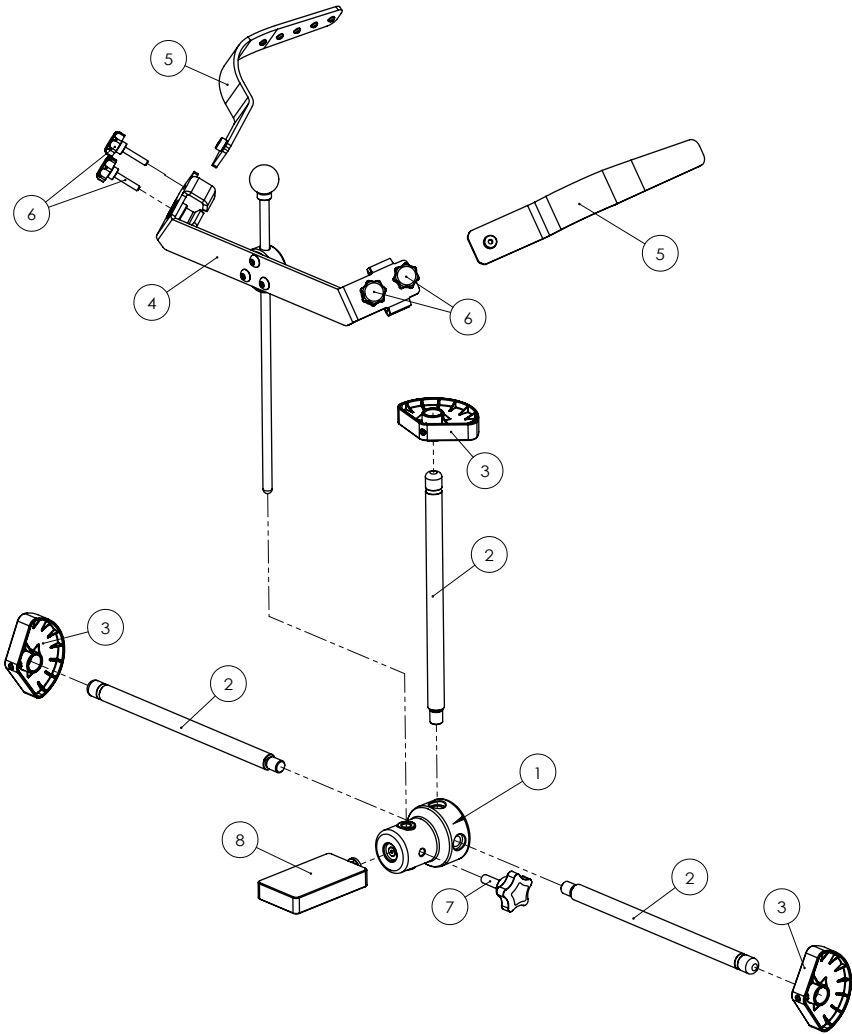

Sharp Align Universal Fixture		
1	Center Base	11
2	Center Base Extension Rod	12
3	Spacer	13
4	Tire Holding Bracket	14
5	Tire Holding Arm	15
6	Holding Arm Adjusting Knob	16
7	Knob	17
8	Sharp Align Sensor	18
9		19
10		20

Environmental Protection



Environmental Protection

Recycle unwanted materials instead of disposing of them as waste. All tools, accessories and packaging should be sorted, taken to a recycling centre and disposed of in a manner which is compatible with the environment.

Warranty

Limited One (1) Year Warranty

Jackco Transnational Inc. warrants "Sharp Align" branded products to the original purchaser against any manufacturing defect in material or workmanship for a period of one (1) year from the original date of purchase. If the defective product is determined to be covered under this warranty, it shall be repaired or replaced at manufacturer's discretion without charge. Provided that the product must be returned with proof of purchase and freight prepaid when returned to the manufacturer. This warranty shall not apply to damage due to accident, negligent use, lack of maintenance, abuse or applications other than the specific function the product is designed for.

No other warranties, expressed or implied, including those of merchantability or fitness for particular purpose shall be applicable to Jackco except as specifically stated herein. In no event shall Jackco be liable to any party for any special, direct, indirect, consequential, punitive damage of any nature caused by the sale or use of the equipment, tool, or product.

Note: This warranty gives the original purchaser specific legal rights which may vary from state to state.



This product is manufactured for
Jackco Transnational Inc.
Made in Taiwan

For Technical Assistance, Contact us at
☎ (626) 582-8055
🌐 www.sharpalign.com